

RECOVERING THE RIFE MICROSCOPE: A HOLOGRAPHIC DEVICE DEVELOPED 50 YEARS “AHEAD OF TIME”.

Introduction:

During the 1930’s there was a gentleman named “Royal Rife” who claimed to have an optical microscope which was capable of 10,000 X’s magnification.

To find out details on Dr. Rife’s work (the Doctor is an Honorary title, however after making the discoveries I have made I will GLADY give Dr. Rife this title, he deserves it!) please visit these websites

<http://www.rife.de/mscope/mscope1.htm>

or

<http://www.rifeenergymedicine.com/AppAH.html>

The problem with Dr. Rife’s claims, as can readily be seen from examining these websites is that there is a well known phenomenon in optics called the “Abbe Limit” Or the FRAUNHOFER DIFFRACTION limit.

What this limit does for optical microscopy is to state that due to problems with the diffraction of light around bodies of the size of the wavelength of visible light (550 to 200 nanometers), the maximum optical magnification (useful) is limited to about 2000 X’s.

Yet Dr. Rife, (as can be seen from the websites) clearly claimed to be obtaining magnifications of the order of 10,000 to 40,000 X’s.

Based on Dr. Rife’s observations of “live, real time” observations of bacteria and viral action(s), Dr. Rife developed the “Rife Ray Device”.

For more detail on the “Rife Ray Device”, I would recommend that one go to the following website:

<http://www.rt66.com/~rifetech/>

There one will find an excellent an very complete discussion of the Rife Ray device. Although Dr. Bare’s work is very complete and technical, it does take some time to work through reading the material. Thus I will attempt to write a paragraph

description of the “Rife Ray Device” and give a tentative, (although not definitive) explanation of how it works.

The “Rife Ray Device” is essentially a “low grade” inert gas MASER (microwave amplification by stimulated emission of radiation).

The “stimulation” is by an RF (Radio Frequency) signal applied to a He/Ne or He/Ar tube. Typically in the 20-30 MHz range.

This RF signal is also AMPLITUDE MODULATED by some sort of audio frequency.

What Dr. Rife discovered was that using his microscope he could observe that as various audio frequencies were applied to the “Ray Device”, he could find a particular frequency for a particular organism which would cause the organism to break apart.

Dr. Bare has built, patented (a variation) and markets the INFORMATION to duplicate the Rife Ray devices.

Because of the TREMENDOUS power of the “medical establishment”, Dr. Bare does not market these devices for “therapeutic” purposes.

If one builds/acquires a “Rife/Bare” device, one does it for one’s own personal “research” and with no claims implied or expressed with regard it’s ability to selectively “lyse” or destroy various micro-organisms “in vitro”. (Or in the human body.)

This bring us again, “full circle” to the “Rife Microscope”, as it is the BASIS for Rife’s various claims with regard observations he made in the 1930’s as to the actions of bacteria and viruses which to this day remain “advanced” and not fully “recovered” at this time.

The problem with the Rife Microscope, is that of the 5 or 6 versions that Rife produced, there exist 3 of them in various private party ownership.

Over the years attempts have been made to “recover” the microscopes. It is known, for instance, that Rife filled the barrels of his microscopes with Glycerin. Some various versions of his microscope have been filled with Glycerin and attempts to observe organism made.

From one of the above websites I will excerpt the following:

Rife No 5 was tested in 1978 while it was at the Wellcome Museum, by a Professor of Physics from Imperial College in London. Practically the whole instrument was dismantled. There seemed nothing particularly remarkable about it except that it had been constructed in such a way as to make the work of microscopy tedious and cumbersome, particularly in respect of focusing the instrument. Using all the original optics it was quite impossible to obtain an image, but using a light-source, eyepiece and objective from a Reichart microscope, a very imperfect image of leukemia blood cells was finally obtained. The image was about 30% larger than would have been expected with the use of a x6 objective and a x40 eyepiece, and this was no doubt due to the prismatic arrangement in the barrel of the microscope. The resolution, However, was extremely poor. It was concluded that it would have been impossible to produce the known photomicrographs with this instrument and it became clear that this explained the late Dr Gonin's complaint that he could obtain no results. One of the original photographs labeled "virus of cancer" was identified as a well-known artifact of optical systems known as "coma". It is merely a photographic rendering of an anomaly produced by defects in the optical system.

This sounds pretty disparaging and almost a total indictment of the claims (by many) that the Rife Microscope is a fraud.

However, it is CLEAR from reading this that the person trying to replicate the original Rife work DID NOT READ ANY OF THE EXISTING WRITINGS BY RIFE or have a background which would lead them ANYWHERE NEAR the resolution of the method of operation of the scope.

When one reads the writings of Rife, one finds out several things which Rife makes clear, quite plainly.

First of all, Rife refers to his Microscope as “An Interference Microscope”.

To continue this discussion and demonstrate the technical reality of the Rife Microscope, I will borrow an illustration from Gary Wade’s fine website:

The problem with the schematic above is that it obscures a very important point with regard the Rife microscope.

Mr. Wade's work is influenced by the erroneous concept that is "about" that Rife's microscope had some peculiar effectiveness due to the "Numerical Aperture" and the length of the optical path.

That is why the "optical path" is traced out with lines and arrows in Wade's schematic. Aside from the fact that this "optical path" does not make sense...i.e. it essentially shows the prism surfaces acting as mirror surfaces, it has nothing to do with the function of the Rife Microscope.

I would enjoy the reader to look at this version of Mr. Wade's drawing:

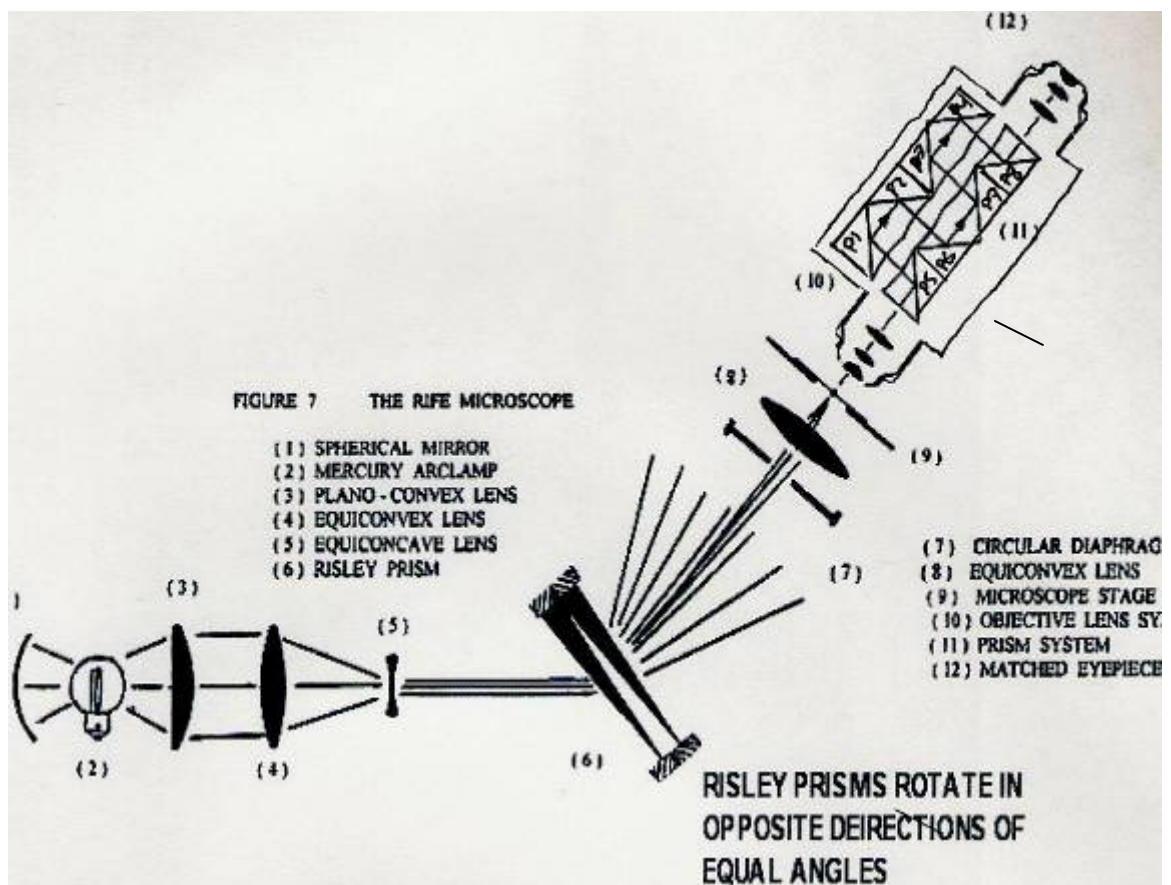

Please note my having drawn in (alas, not clearly but I believe one can still make out the point) the outlines of the 8 prisms which have been noted to have existed in Rife's scope.

Prisms P5 and P6, and P7 and P8 are "back to back" and, I believe, optically connected. I also believe that prisms P2 and P3, despite being shown above as "back to back" are NOT optically connected.

The reason I believe this to be the case will become clear upon the following discussion of the work of Courjon and Boulabois (Journal of Optics, Paris, 1979, copy attached.)

As the result of 2 months of searching on the Internet, I have located two pivotal papers on Holographic Microscopes. They are attached to this document, but their citations are:

“Real Time Holographic Microscopy Using a Peculiar Holographic Illuminating System and a Rotary Shearing Interferometer”,

By D. Courjon and J. Bulabois,

Journal of Optics, Paris, 1979, Volt 10, No. 3

And:

“High Depth of Field Microscopic Imaging Using an Interferometric Camera”

P. Potuluri, M. R. Fetterman and D. J. Brady

*Beckman Institute, University of Illinois at Urbana-Champaign,
Urbana, IL 61801 dbrady@duke.edu*

*This is from 21 May 2001 / Vol. 8, No. 11 / OPTICS EXPRESS 630
Received March 27, 2001; Revised May 18, 2001*

The first paper describes in “theory” a holographic microscope. Part of the actual “practice” is accomplished. It is not clear exactly how much of the following diagram is “accomplished” to obtain the images shown in the paper.

However, the implication is that the concept is complete. Here is the primary Schematic from the paper:

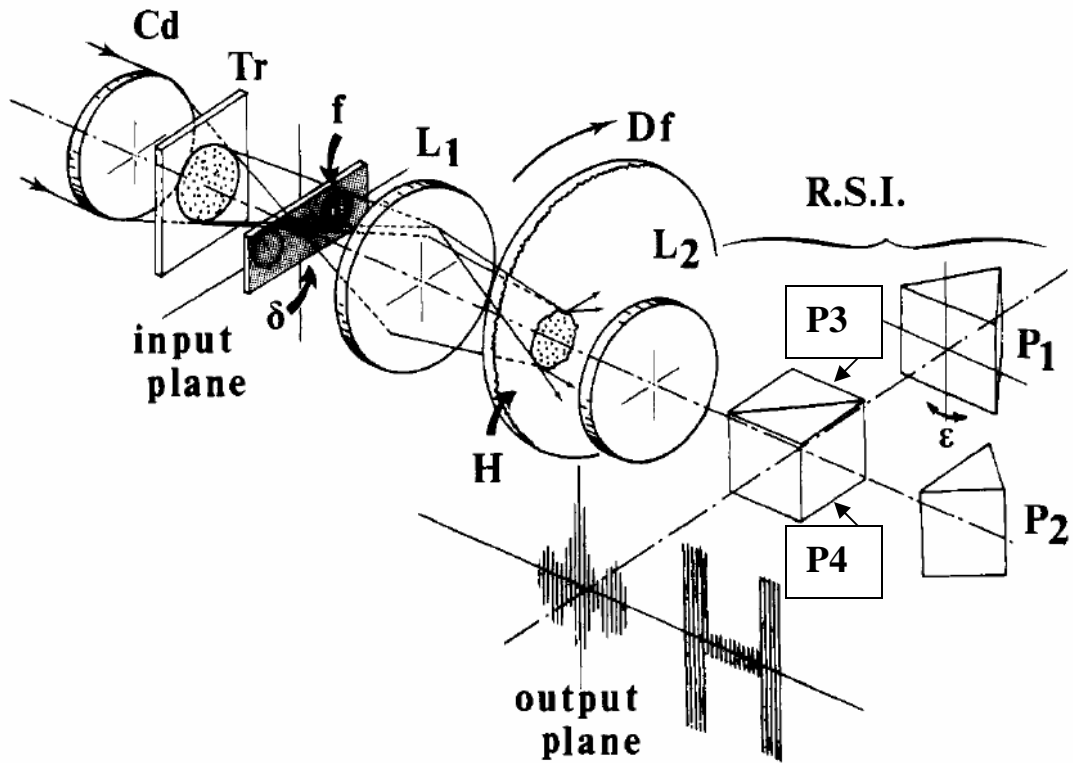

This is Figure 3. from the Courjon-Bulabois paper. This schematic cannot be analysed in detail without another figure from the paper, figure 2. shown below:

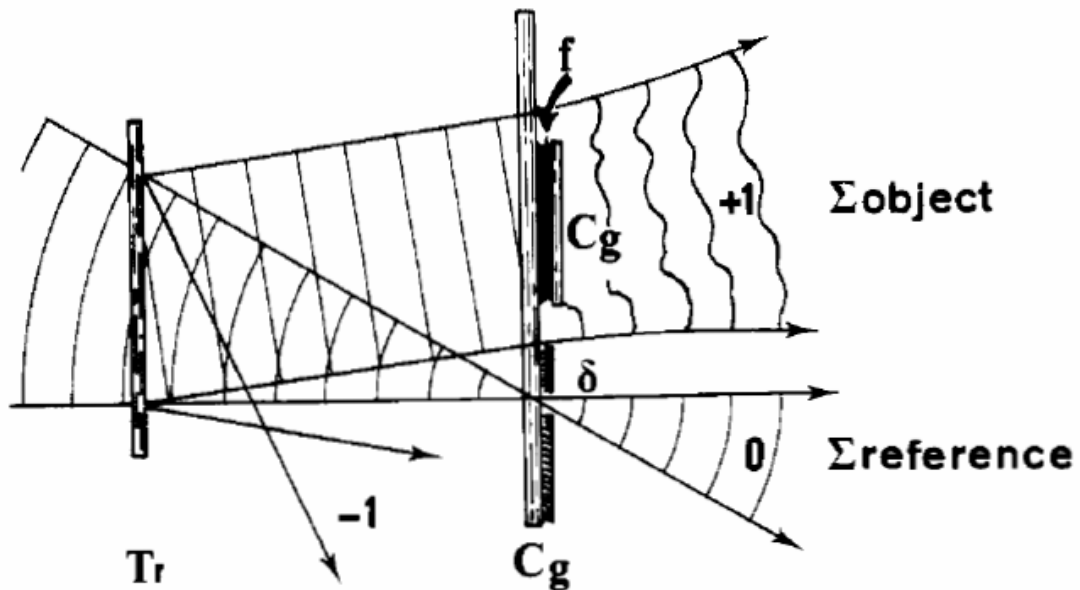
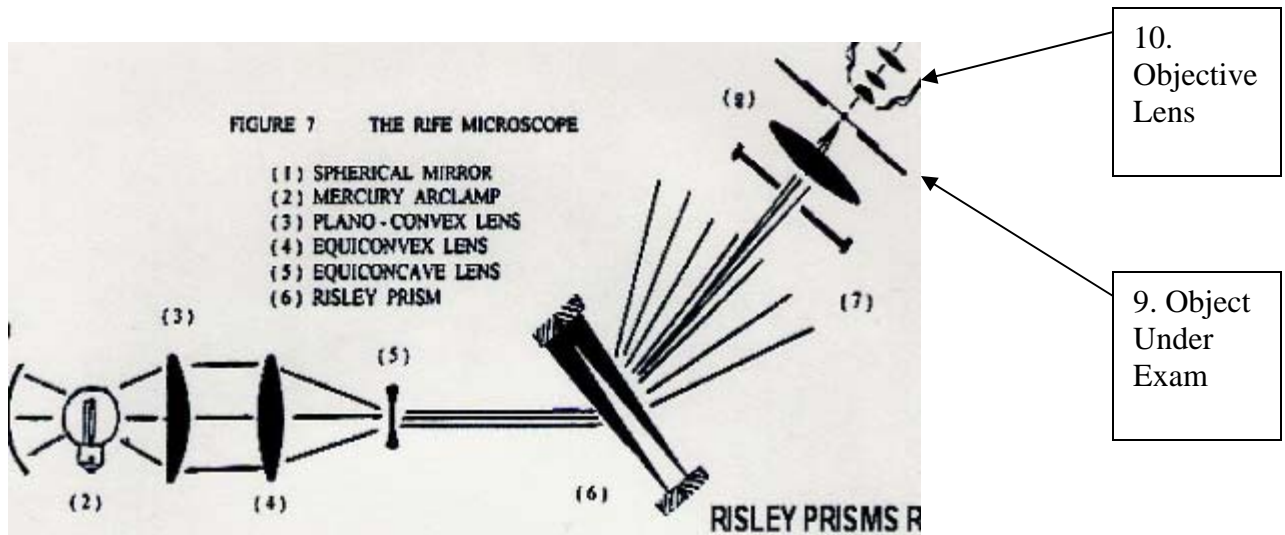

FIG. 2. — Illumination of the object and the pinhole. Tr, holographic transparency, Cg cover glasses, f information, δ , pinhole.

Figure 2. is a detail of the area labeled “Tr and Input Plane” in Figure 3.

What Figure 2 illustrates is that the object being “examined” (or optically “enlarged”) with the holographic microscope needs to be exposed to the illuminating coherent/monochromatic light and an interference pattern (holograph, fundamentally) formed with a reference beam which is split through a pinhole.

We shall start with this part of the device and parallel the “Rife Microscope” from this point forward:



In the above 7. is a “circular diaphragm” and 8. is an convex lens.

What we see happening in the above section of the Rife scope is the following:

1. Between 1 to 6, the creation of a strong collimated beam.
2. At step 6 the selection of a precise section of the spectrum of the light coming from the “mercury arc lamp”.

There are several points here which should be made:

First, the light coming from the source by the time it strikes the “microbe” under examination is very much a “laser light”. I.e., mono-chromatic and coherent.

Secondly, Rife makes it very clear in his writings that his goal was to find a particular light spectrum which would cause the “microbe” to self-fluoresce.

Our contention is that upon the self-fluorescence of the organism, the combined light “signal” going into the objective lens set at point 10 in the above is the

equivalent of the combined object and pinhole reference light of the D. Courjon and J. Bulabois paper.

Thus the optical “signal” at L1 in the C&B paper is identical to the signal that Rife would have had at his objective lens.

From this point on we come to another three key contentions:

- 1. The prism sets in the Rife scope, being P1-P8 perform the same “inverse Fourier transform(s)” that the prisms P1-P4 accomplish in the C&B paper.**
- 2. The Glycerin in the Rife microscope serves the same function as Df in the C&B paper. (This is the “rotating shearing” device, which supplies optical decoherence to the interference signal.)**
- 3. The Glycerin would not in and of itself supply that optical decoherence except that it is “spiked” with a slight organic dye doping. Probably a methyl Red or the like.**

It is believed that the parallels between Rife’s microscope and his method of operation supply us with a complete picture of the “how and why” of the functionality of the device when examined in light of the Holographic microscope.

In the C&B Paper, the ability of the Holographic microscope to magnify an image beyond the normal “Abbe Limit” is explained mathematically thus:

II. b. — Interferometric part, reconstruction and magnification step

The apparatus is a modified Michelson interferometer in which the planar mirrors are replaced by two Porro prisms. The capability of such an interferometer to perform Fourier transforms has been shown [8] and yet used in holography [9, 12] and in M.T.F. measurements [11]. In the latter case the authors give a mathematical development of the optical processing. So if $g(\xi, \eta)$ is the intensity distribution in the diffuser plane (Fourier hologram of the information f), the intensity in the output plane is given by equation [19] of the reference [11].

$$(1) \quad E(u, v) \propto 1 + \left| \frac{d(u, v)}{d(0, 0)} \right| \cos \varphi(u, v)$$

where

$$(2) \quad d(u, v) = \iint_{-\infty}^{+\infty} G(\xi, \eta) \times \\ \times \exp \left[-j 2 \pi (u\xi + v\eta) \right] d\xi d\eta .$$

The above equations express the Fourier transform of the image by the optical processing. In the above expressions a small “g” is used in the text area, and it reflects the “intensity distribution” without phase information, where the $G(\xi, \eta)$ in the integral represents a more correct vector quantity with the phase information in it.

The C&B Paper goes on to analyze the output intensity distribution thus:

Thus in the output plane the intensity distribution is characterized by a cosine modulation, the visibility of which is proportional to the Fourier transform of $G(\xi, \eta)$. It consequently describes the reconstructed images of f .

In the output plane with suitable reference axes the geometrical coordinates (x, y) corresponding to the frequencies (u, v) are

$$x = \frac{\lambda D}{2 \sin \varepsilon} u \quad y = \frac{\lambda D}{2 \sin \varepsilon} v$$

where D is the optical path from the diffuser plane to the output plane and ε the rotation angle of prisms. In comparison with the Fourier transform by classical diffraction, let us write the geometrical coordinates (x', y') for the same value of frequencies (u, v)

$$x' = \lambda D u \quad y' = \lambda D v$$

C&B Continue to derive:

The ratio x/x' (or y/y') is proportional to $(2 \sin \epsilon)^{-1}$, so that by rotating the prisms the lateral magnification ranges from $\gamma = 1/2$ to $\gamma = \infty$.

Hence the sizes of reconstructed images can be chosen at will by the adjustment of the angle ϵ .

Thus on a theoretical basis they believe that the image magnification is “unlimited”.

They do, however, supply the following limitation on the “resolution” of the image:

“The main limitation is connected with the requirement of using a reference pinhole, the dimension of which must be smaller than the size of the smallest details of the object, for example 50 pm for the previous grating. Moreover, the finite size of the average graininess of the diffuser introduces another limitation of resolution. In other words such a system allows large magnifications but with a limited bandwidth.” (Page 127 of C&B’s paper.)

Two more key contentions about the Rife device thus need to be elucidated:

- 1. The “pinhole” size in the Rife Microscope is the SIZE OF THE ORGANISM UNDER EXAMINATION.**
- 2. The “graininess” of the diffuser (or optical de-coherence device) is on the molecular level. It is related to the interaction of the light “signal” with the organic dye in the Glycerin.**

Although the author of this work has known of the Rife Microscope for about 5 years, only in the last three months has the author undertaken a serious study of the device.

The first two months involved study of many optics references, including but not limited to:

- 1. “Optics” by Eugene Hecht, Second Edition, Addison-Wesley, 1987.**
- 2. “Engineering Optics”, by Keigo Iizuka, Second Edition, Springer-Verlag, 1983.**

I’m particularly indebted to Dr. Iizuka for an incredibly fine text, with numerous references and tremendous examples, which was very important in helping me locate the work by the French researchers.

During the time period of December 31st, 2003 to January 6th, 2004 I was on travel visiting my Mother in Peoria AZ. Although there were a variety of “domestic tasks” involved with this trip, I did have enough time to continue work on the Rife microscope and it was during this time that I was able to locate the papers by

D. Courjon and J. Bulabois, and the paper by P. Potuluri, M. R. Fetterman and D. J. Brady.

The work by Potuluri, Fetterman, and Brady, although not discussed in detail here, gave me further evidence of the reality of Courjon and Bulabois theoretical claims, as the PFB paper details actual construction and application of a “Rotating/Shearing Interferometric Holographic Microscope”.

Now we come to the section of this work that perhaps should be titled:

REDUCTION TO PRACTICE OF THE RIFE MICROSCOPE

To begin with, let us show the following picture:

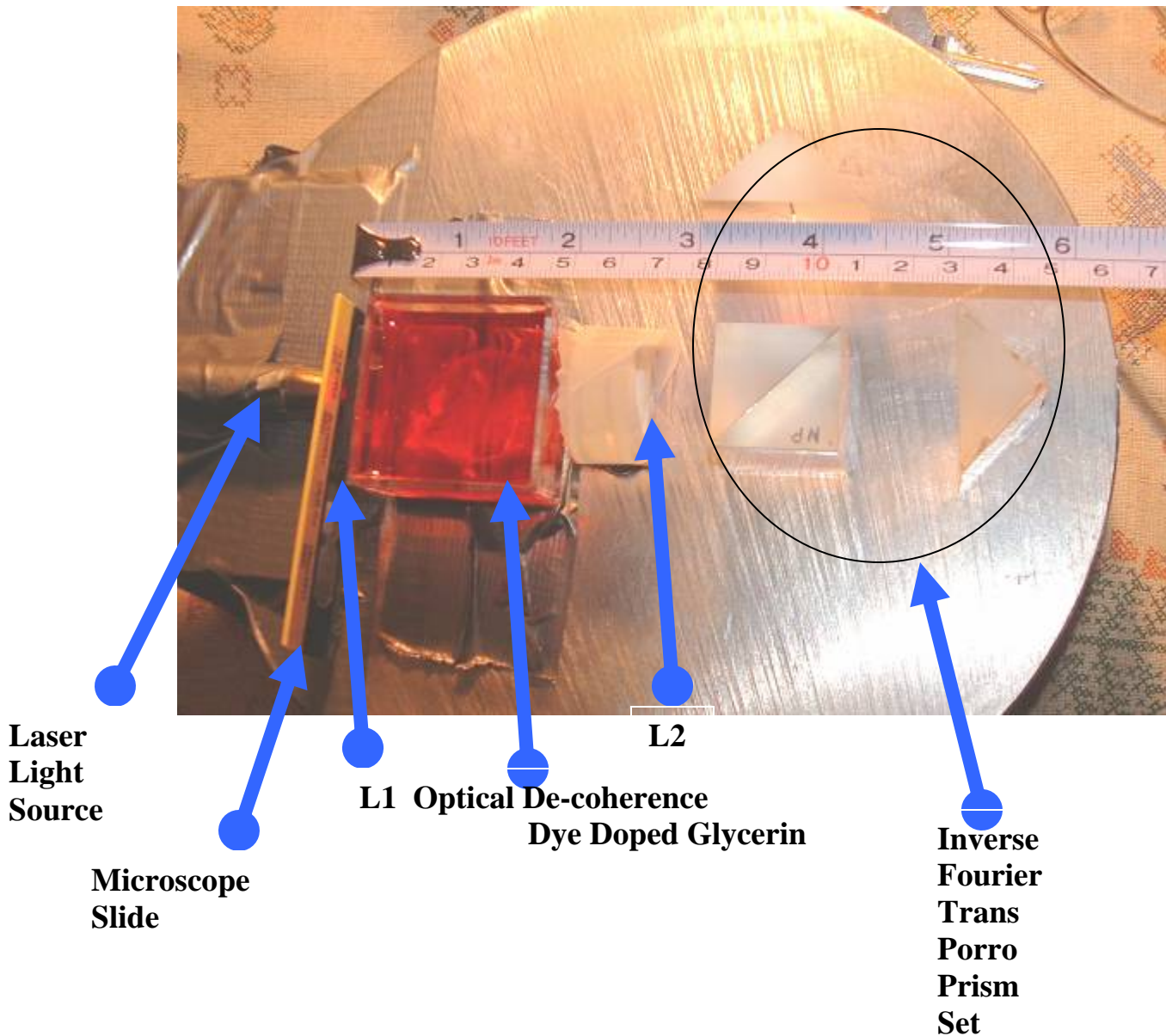

A series of experiments were preformed with this test set up over the time of Saturday, the 10th of January 2004 and into Sunday, the 11th of January 2004.

The experiments allowed the author to determine that there was good evidence of the functionality of the “dye-doped” glycerin to accomplish the needed “optical de-coherence” to obtain the complete inverse transform of the “microscopic holograph”, which would be a key element in proving the functionality of the Rife Microscope.

Below is a single frame from an AVI, with the image (clearly seen during the AVI, as moving The slide with the fruit fly, moves the image and makes it stand out..) of the fruit fly circled.



The image of the fruit fly is within the circle above.

Removal of the “optical de-coherence material yields this image:



What is clearly seen in the AVI is that moving the slide up and down, about 2-3 mm gives No recognizable imaging within the circled area when the optical de-coherence material is removed.

Now it should be noted that what this testing has established, in brief is:

- A. The dye doped glycerin acts as a “molecular level” optical de-coherence material.**
- B. By implication, because of the complete disappearance of the image with the removal of the de-coherence material, the image IS a holographic reconstruction, demodulated by the inverse Fourier action of the Porro prism set.**

C. Every aspect of the Rife scope from the origin of the interference waves at the specimen on has been both theoretically and experimentally established.

What remains to be done now is two fold:

- 1. Some means to recreate the “self fluorescent/coherent reference light on a microscopic specimen needs to be constructed.**
- 2. By a more formal arrangement, (I.e., use of an optically “clean” de-coherence container...something of better optical quality than the inexpensive “plastic box” used for the first work and use of a more formalized L1, L2 set [and locations thereof], and a more formalized Porro prism arrangement [calculated with info from Mertz’s “Transformations in Optics” perhaps?]) it would be hoped that a more precise and clear image may be obtained.**

This will take some time and effort. But in view of the end result, it should be worth the effort. The end result should be also two fold:

- A. A vindication of Rife, and subsequent formal basis to regard the “follow through” of his work (i.e., the Rife Ray device, some of his recorded observations of the behavior of micro-organisms) as being very legitimate and deserving of close study.**
- B. The construction of a practical optical device for in vivo studies of micro-organisms from small bacteria size (Tuberculosis for example) to virus size. Something which does not occur presently, due to the need of vacuum processing in electron microscopy.**

